



AN-9012

Induction Heating System Topology Review

1. Introduction

All induction heating (IH) applied systems are developed using electromagnetic induction, first discovered by Michael Faraday in 1831. Electromagnetic induction refers to the phenomenon by which electric current is generated in a closed circuit by the fluctuation of current in another circuit next to it. The basic principle of induction heating, which is an applied form of Faraday's discovery, is the fact that AC current flowing through a circuit affects the magnetic movement the secondary circuit located near it. The fluctuation of current inside the primary circuit provided the answer as to how the mysterious current is generated in the neighboring secondary circuit. Faraday's discovery led to the development of electric motors, generators, transformers, and wireless communications devices. Its application, however, has not been flawless. Heat loss, which occurs during the induction heating process, has been a major headache, undermining the overall functionality of a system. Researchers sought to minimize heat loss by laminating the magnetic frames placed inside the motor or transformer. Faraday's Law was followed by discoveries such as Lenz's Law. This law explains that inductive current flows inverse to the direction of changes in induction magnetic movement.

Heat loss, occurring in the process of electromagnetic induction, can be turned into productive heat energy in an electric heating system by applying this law. Many industries have benefited from this breakthrough by implementing induction heating for furnacing, quenching, and welding. In these applications, induction heating has made it easier to set the heating parameters without the need of an additional external power source. This substantially reduces heat loss, while maintaining a more convenient working environment. Absence of any physical contact with heating devices precludes unpleasant electrical accidents. High energy density is achieved by generating sufficient heat energy within a relatively short period of time.

Demand for better quality, safer, and less energy-consuming products is rising. Products using IH include electronic rice cookers and pans. Safe, efficient, and quick heating appliances attract more customers. This document describes induction heating, power systems, and IH applications.

2. Basics of Induction Heating (IH)

Induction heating is comprised of three basic factors: electromagnetic induction, the skin effect, and heat transfer. The fundamental theory of IH, however, is similar to that of a transformer. Electromagnetic induction and the skin effect are described in this section. Figure 1 illustrates a basic system, consisting of inductive heating coils and current, to explain electromagnetic induction and the skin effect. Figure 1-a shows the simplest form of a transformer, where the secondary current is in direct proportion to the primary current according to the turn ratio. The primary and secondary losses are caused by the resistance of windings and the link coefficient between the two circuits is unity. Magnetic current leakage is ignored here.

When the coil of the secondary is turned only once and short-circuited, there is a substantial heat loss due to the increased load current (secondary current). This is demonstrated in Figure 1-b. Figure 1-c shows the concept of induction heating where the energy supplied from the source is of the same amount as the combined loss of the primary and secondary. In these figures, the inductive coil of the primary has many turns, while the secondary is turned only once and short-circuited. The inductive heating coil and the load are insulated from each other by a small aperture. The next phase of the skin effect occurring under high frequency is presented in Section 2.2.

Because the primary purpose of induction heating is to maximize the heat energy generated in the secondary, the aperture of the inductive heating coil is designed to be as small as possible and the secondary is made with a substance featuring low resistance and high permeability. Nonferrous metals undermine energy efficiency because of their properties of high resistance and low permeability.

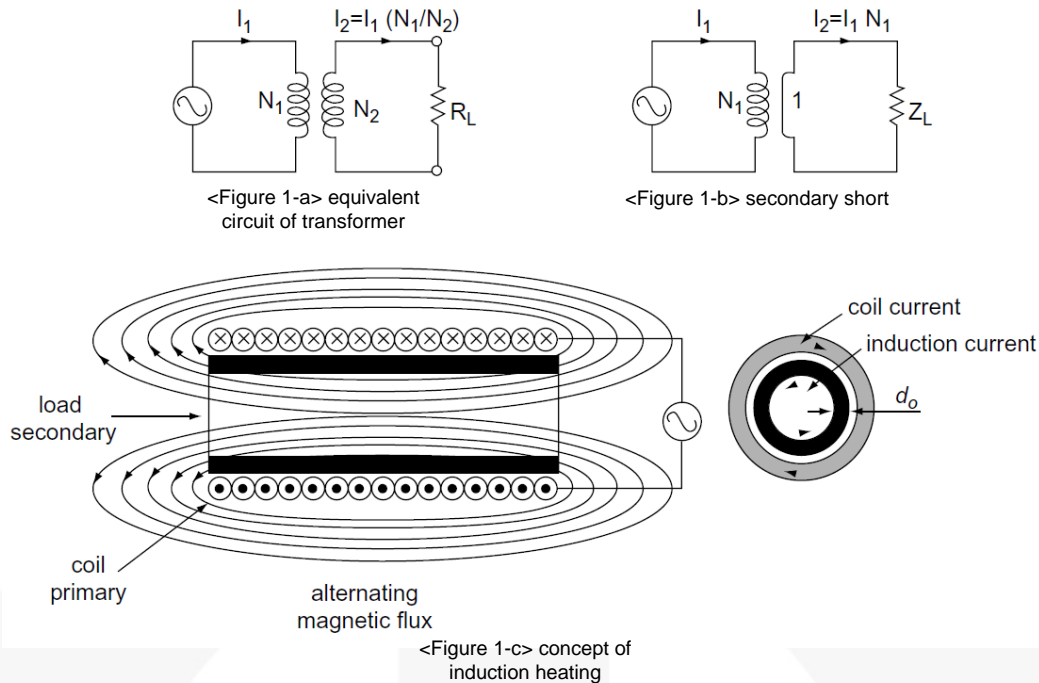

Figure 1. Basics of Induction

2.1. Electromagnetic Induction

As shown in Figure 1, when the AC current enters a coil, a magnetic field is formed around the coil, calculated according to Ampere's Law as:

$$\int H di = Ni = f \quad (1)$$

$$\phi = \mu HA$$

An object put into the magnetic field causes a change in the velocity of the magnetic movement.

The density of the magnetic field wanes as the object gets closer to the center from the surface. According to Faraday's Law, the current generated on the surface of a conductive object has an inverse relationship with the current on the inducting circuit as described in Equation (2). The current on the surface of the object generates an eddy current, calculated as:

$$E \frac{d\lambda}{dt} = N \frac{d\phi}{dt} \quad (2)$$

As a result, the electric energy caused by the induced current and eddy current is converted to heat energy, as shown in Equation (3).

$$P = \frac{E^2}{R} = i^2 R \quad (3)$$

Resistance is determined by the resistivity (ρ) and permeability (μ) of the conductive object.

Current is determined by the intensity of the magnetic field. Heat energy is in an inverse relationship with skin depth, which is described in Section 2.2.

If an object has conductive properties like iron, additional heat energy is generated due to magnetic hysteresis. The amount of heat energy created by hysteresis is in proportion to the size of the hysteresis. In this document, this additional energy is ignored because it is far smaller (less than 10%) than the energy generated by induction current.

2.2. Skin Effect

The higher the frequency of the current administered to the coil, the more intensive is the induced current flowing around the surface of the load. The density of the induced current diminishes when flowing closer to the center, as shown in Equations (4) and (5) below. This is called the "skin effect" or "Kelvin effect." From this effect, one can infer that the heat energy converted from electric energy is concentrated on the skin depth (surface of the object):

$$i_x = i_o e^{-x/d_o} \quad (4)$$

where:

i_x = distance from the skin (surface) of the object, current density at x ;

I_o = current density on skin depth ($x=0$);

d_o = a constant determined by the frequency (current penetration depth or skin depth); and:

$$d_o = \sqrt{\frac{2\rho}{\mu\omega}} \quad (5)$$

where:

ρ = resistivity;

μ = permeability of the object; and

ω = frequency of the current flowing through object.

Equation (5) states that the skin thickness is determined by the resistivity, permeability, and frequency of the object. Figure 2 below is the distribution chart of current density in relation to skin thickness.

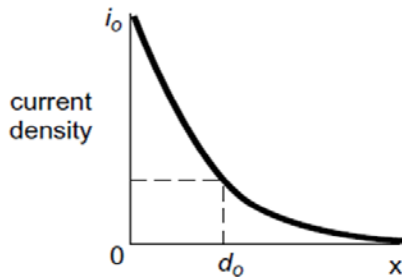

Figure 2. Distribution Chart of Current Density and Skin Thickness

3. Topology of Power System

Generally, semiconductor switching devices operate in Hard Switch Mode in various types of Pulse Width Modulation (PWM) DC-DC converters and DC-AC inverter topologies employed in power systems. In this mode, a specific current is turned on or off at a specific voltage whenever switching occurs, as shown in Figure 3. This process results in switching loss. The higher the frequency, the greater the switching loss, which obstructs efforts to raise the frequency. Switching loss can be calculated as shown in Equation below. Switching also causes an EMI problem, because a large amount of di/dt and dv/dt is generated.

$$P_{sw} = \frac{1}{2} V_{sw} I_{sw} f_s (t_{on} + t_{off}) \quad (6)$$

where:

- P_{sw} = switching loss [W];
- V_{sw} = switching voltage [V];
- I_{sw} = switching current [A];
- f_s = switching frequency [kHz];
- t_{on} = switch turn-on time [s]; and
- t_{off} = switch turn-off time [s].

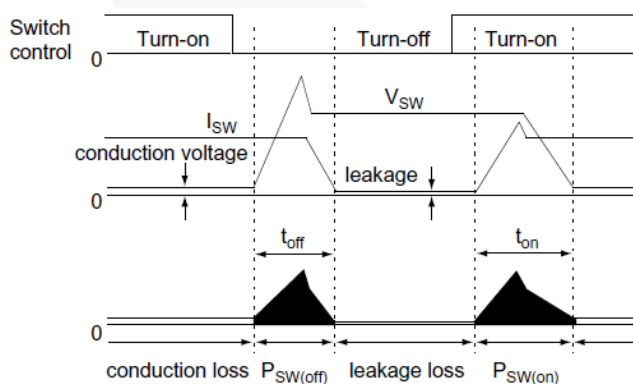

Figure 3. Waveform of a Switching Device

Raising the switching frequency reduce the size of a transformer and filter, which helps build a smaller and lighter converter with high power density. But switching loss undermines the efficiency of the entire power system in

converting energy, as more losses are generated at a higher frequency. Switching loss can be partly avoided by connecting a snubber circuit parallel to the switching circuit. However, the total amount of switching loss generated in the system remains the same. The loss avoided has been moved to the snubber circuit.

Higher energy conversion efficiency at high-frequency switching can be obtained by manipulating the voltage or current at the moment of switching to become zero. This is called “soft switching,” which can be subcategorized into two methods: Zero-Voltage Switching (ZVS) and Zero-Current Switching (ZCS). ZVS refers to eliminating the turn-on switching loss by having the voltage of the switching circuit set to zero right before the circuit is turned on. ZCS avoids the turn-off switching loss by allowing no current to flow through the circuit right before turning it off. The voltage or current administered to the switching circuit can be made zero by using the resonance created by an L-C resonant circuit. This is a “resonant converter” Topology.

In ZCS, the existing inductance is absorbed into the resonant circuit, eliminating the surge in voltage in a turn-off situation. A voltage surge resulting from an electric discharge of junction capacitance, which occurs upon turning on the switching circuit, cannot be avoided. This method causes switching loss ($0.5CV^2 f$). ZCS, however, is free from this defect and makes both the existing inductance and capacitance be absorbed by the resonant circuit. This eliminates the chance of causing a surge in current at turn-off (caused by inductance) or turn-on (by capacitance) conditions. ZVS enables switching with less loss, while substantially reducing the problem of EMI at high frequency. This difference in features make ZVS more attractive than ZCS in most applications.

As a resonant converter provides most of the energy conversion efficiency in a power system by minimizing switching loss, it is widely used in a variety of industries. This is also the reason the converter is adopted in the IH power system Topology, which is described in detail in this document. Power systems for home appliances, such as electronic rice cookers, generally employ a ZVS resonant converter. ZVS converters can be classified into two major types: a half-bridge series resonant converter and a quasi-resonant converter. These are studied in detail in Section 4 of this document.

3.1. Resonant Inverter

The resonant circuit of a resonant inverter consists of a capacitor, an inductor, and a resistor / source of resistance. Two types of resonant inverters are generally used: a series resonant circuit and a parallel resonant circuit. Figure 4 shows these two common types. When power is connected, electric energy, as shown in Equation (8), is stored in the inductor and transferred to the capacitor. Equation (9) simplifies the calculation of the amount of energy stored in the capacitor sent to the inductor. Resonance occurs while the inductor and the capacitor exchange the energy. The total amount of energy stored in the circuit during resonance

remains unchanged. This total amount is the same as the amount of energy stored at peak in the conductor or capacitor.

$$i = \sqrt{2I} \sin \omega t [a] \quad (7)$$

$$V_C = \frac{1}{C} \int idt = -\frac{\sqrt{2I}}{\omega C} \cos \omega t [J] \quad (8)$$

$$E_L = \frac{1}{2} Li^2 = LI^2 \sin^2 \omega t [J] \quad (9)$$

$$E_C = \frac{1}{2} CV_C^2 = \frac{I^2}{\omega^2 C} \cos^2 \omega t = LI^2 \cos^2 \omega t [J] \quad (10)$$

$$E_L + E_C = LI^2 (\sin^2 \omega t + \cos^2 \omega t) = LI^2 [J] \quad (11)$$

As some energy is lost due to resistance in the resonance process, the total amount of energy stored in the inductor decrements in each resonant exchange. The resonance frequency, which is the speed of energy transfer, is determined by capacitance (C) and inductance (L), as shown in Equation (15).

The inductive reactance and the capacitive reactance are summarized in Equations (12) and (13), respectively. The size of impedance in a series resonant circuit is determined as shown in Equation (14).

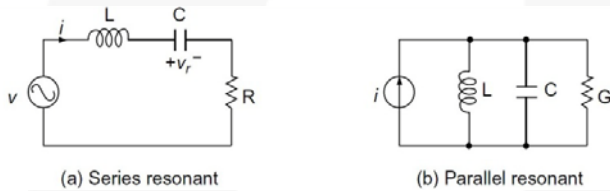

Figure 4. Resonant Circuit

$$X_L = j\omega L = j2\pi fL [\Omega] \quad (12)$$

$$X_C = \frac{1}{j\omega C} = \frac{1}{j2\pi fC} [\Omega] \quad (13)$$

$$|Z| = \sqrt{R^2 + \left(\omega L - \frac{1}{\omega C}\right)^2} [\Omega] \quad (14)$$

At the resonance frequency, the inductive reactance of Equation (12) and the capacitive reactance of Equation (13) become the same, i.e. the voltage of the power source and the current in the circuit stay at the same level. The resonance frequency can be summarized as shown in Equation (15). The current in the circuit reaches its peak when the source frequency becomes identical to the resonance frequency. It decrements when the source frequency gets higher or lower than the resonance frequency:

$$2\pi fL = \frac{1}{2\pi fC} \Rightarrow f_0 = \frac{1}{2\pi\sqrt{LC}} [Hz] \quad (15)$$

The properties of reactance in a circuit are called “special” impedance, which can be described as shown in the following equation:

$$Z_0 = X_L = X_C = \omega_0 L = \frac{1}{\omega_0 C} = \sqrt{\frac{L}{C}} \quad (16)$$

$$X_0^2 = X_L \times X_C = \frac{L}{C}$$

The selection ratio of a half-bridge series resonant circuit is as shown in the following equation:

$$Q = \frac{\omega_0 L}{R} = \frac{1}{\omega_0 CR} = \frac{Z_0}{R} \quad (17)$$

As shown in Equation (17), the smaller the resistance is than the inductance, i.e. when the source frequency gets closer to the resonance frequency, the sharper the frequency curve of Figure 5 and the bigger the value of Q. The numerator is the energy accumulated in the inductor during resonance and the denominator is the average amount of energy consumed in resistance in each cycle. The frequency curve demonstrates the relationship between current/output energy and source frequency when the source voltage of the resonant circuit is set at equal. The current and output energy reaches its maximum value at resonance frequency.

In the area where the switching frequency is lower than the resonance frequency, the inductive reactance has a direct relationship with the switching frequency. In other words, the lower the frequency, the smaller the inductive reactance. According to Equation (13), the capacitive reactance is in inverse relationship with the frequency. As the reactance becomes more capacitive, the current gets higher than the voltage in status. When the switching frequency increases (in Equation (14)), impedance increases, enlarging the amount of output energy, as shown in Figure 5. In the opposite situation, a lower switching frequency leads to a smaller impedance, causing the output energy to decrement.

In the area where the switching frequency is higher than the resonance frequency, the higher the switching frequency, the bigger the inductive reactance. The value of the capacitive reactance becomes smaller according to Equation (13). The higher inductive reactance causes the current to be lower than the voltage in status. In this situation, a higher switching frequency is accompanied by an increase of impedance (Equation (14)), causing the output energy to be lower (as shown in Figure 5). When the switching frequency goes down, the impedance decreases, raising the output energy (as in Equation (14)).

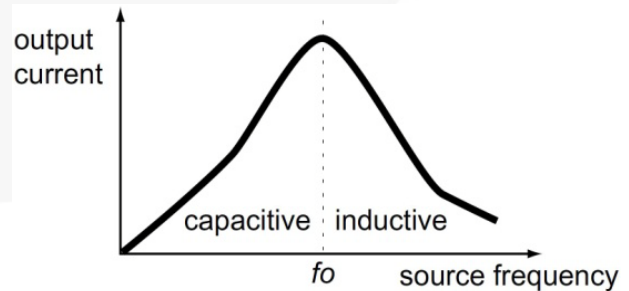

Figure 5. Frequency Curve

4. Induction Heating Applications

Advanced technology in developing semiconductor chips switching at a high frequency has made it possible to introduce new switching devices with sophisticated functions in a smaller size at a lower price. The induction heating system, once dominant only in some specific areas, like guided missiles, has opened a new phase in developing highly efficient electronic home appliances, such as rice cookers. This section presents the operating theory of an IH rice cooker, a power system as a whole, and more detailed description of the controlling circuit in a power system.

4.1. Operating Theory of an IH Rice Cooker

The concept of induction heating, employed in the application of an IH rice cooker, is explained in Section 2. This concept can be simplified as follows: First, convert the AC current coming from the power source to DC using a rectifier. Then, connect this DC current to a high-frequency switching circuit to administer high-frequency current to the heating coil. According to Ampere's Law, a high-frequency magnetic field is created around the heated coil. If a conductive object, e.g. the container of a rice cooker, is put inside the magnetic field, the induced voltage and an eddy current are created on the skin depth of the container as a result of the skin effect and Faraday's Law. This generates heat energy on the surface of the container. Rice is cooked by using this heat energy.

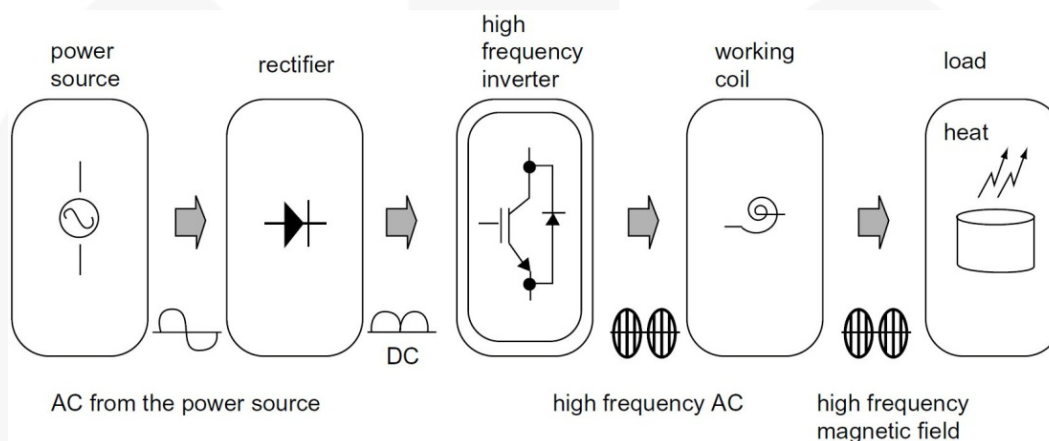

Figure 6. Operating Theory of IH Rice Cooker

4.2. Power System of an IH Rice Cooker

There are two types of topology used in a power system, mentioned in Section 3: a half-bridge series resonant inverter and a quasi-resonant inverter. These two topologies have their own merits and demerits. The merits of a half-bridge series resonant inverter are stable switching, low cost, and a streamlined design. As the voltage of the circuit is limited to the level of the input voltage, the switching circuit can have low internal pressure, which helps reduce cost. The design of the switching control component, inside a circuit, can be streamlined. There are also some demerits. As the half-bridge method requires two switching circuits, the overall working process becomes more complicated and the size of the heat sink and PCB are larger. In addition, gate operating circuits must be insulated.

One of the merits of a quasi-resonant inverter is the need for only one switching circuit. This enables a relatively small design for the heat sink and PCB, making the working process simpler. Another strong point is the fact that the system ground can be shared. A quasi-resonant inverter is not free from defects: switching is relatively unstable and high internal pressure, caused by the resonant voltage administered to both sides of the circuit, pushes up the cost

of the circuit. The design for the controlling component is more complicated. As mentioned earlier, technological improvements in high-frequency semiconductor switching devices has led to innovation in terms of lower prices, higher performance, and high reliability. Quasi-resonant inverters are now generally used because of the smaller heat sink and PCB size and simpler operating process. The following describes the operation of a half-bridge series resonant inverter and a quasi-resonant inverter.

Half-Bridge Series Resonant Inverter

A variety of design methods are available for a power system using a half-bridge series resonant inverter. Figure 7 is a block diagram of a power system in a simplified form with reliability and economy factored in. This system is comprised of an AC power supply, main power circuit, control circuit, input current detection circuit, resonant current detection circuit, and gate operation circuit. All the necessary procedures for designing and testing the system are shown in the block diagram. The drawing does not contain the heater and cooling fan. The operation of a power system as a whole is illustrated in the Figure 7.

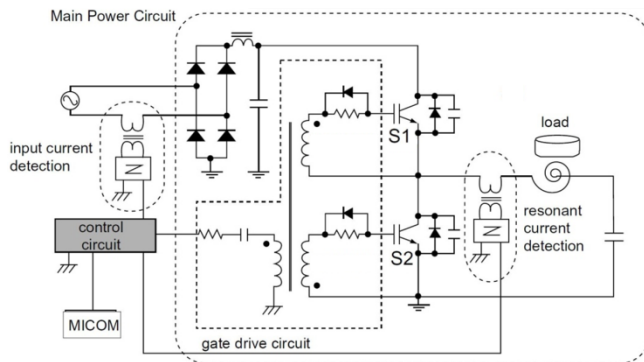

Figure 7. Half-Bridge Series Resonant Inverter

The AC (220 V/60 Hz) power passes through the rectifier to be transmitted to the capacitor. Capacitors in existing power systems are too small in capacity to do the leveling work, leading to the creation of rectified current in 120 Hz, which is not the proper level for DC operation. The system for an IH rice cooker, however, does not require a big capacitor to make DC more leveled, as the primary purpose of the system is to generate heat energy. Rather, the rugged form of DC helps improve the power factor of the system. In this system, the leveling capacitor serves as a filter preventing the high frequency current from flowing toward the inverter and from entering the input part. Input current becomes the average of the inverter current and the ripples flow to the leveling capacitor.

The voltage passing the leveling capacitor is turned into a square wave in the process of high-frequency switching in the inverter. The high-frequency harmonics in the square wave are eliminated by the L_r , C_r filter. The square wave enables resonance in the resonant circuit, which in turn, creates a magnetic field around the resonant inductor affecting the load (rice container). Eddy currents are formed around the surface of the object, generating heat energy.

The input current flowing through the AC input section to the rectifier and the resonant current flowing through the inverter to the resonant circuit are input to the control circuit. To control the maximum level of input and resonant current, the control circuit sets the switching frequency of the inverter, administering it to the gate of the inverter switch via the gate operating circuit.

Main Power Circuit

The main power circuit employs a half-bridge series inverter switching at a high frequency, as shown in Figure 8. The switching circuit consists of an Insulated Gate Bipolar Transistor (IGBT). Zero voltage / current turn-on switching is enabled by turning on the IGBT while the diode is in turn-on period. The resonant circuit comprises of resonant inductance (L_r) and resonant capacitance (C_r). The capacitors, C_1 and C_2 , are the lossless turn-off snubbers for the switches, S_1 and S_2 .

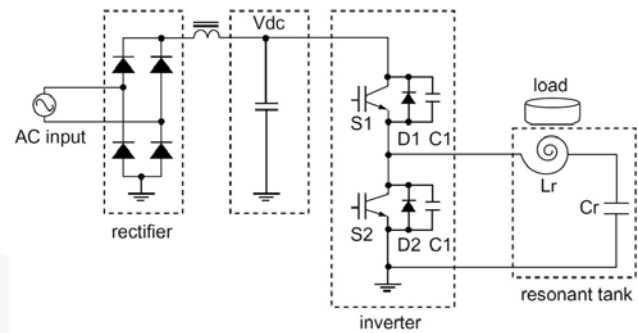

Figure 8. Main Power Circuit

A circuit equivalent to a resonant circuit is described in Figure 9. The load in circuit (a) is equivalent to the circuit in (b) where the transformer has resistance connected to the secondary circuit. This can be simplified as in the circuit (c); where R^* , L^* , and C_r are directly connected. R^* in (c) indicates the resistance of the primary circuit of the transformer converted from the secondary. L^* means the inductor on the primary side of the transformer (L_r), which is a resonant inductor combining the leakage inductor and the secondary inductor.

According to the actual measurement of the system, $L^*=52.7 \mu\text{H}$ and $C_r=0.8 \mu\text{F}$, which leads to the following formula of resonance frequency, f_0 :

$$f_0 = \frac{1}{2\pi\sqrt{L^*C_r}} = 24.5[\text{kHz}] \quad (18)$$

With regard to the switching frequency explained in Section 3, the inductive area has more advantages than the capacitive area in many aspects.^[18] The switching frequency is set at 28 kHz, higher than the resonance frequency, to avoid noise generated in the audio frequency band.

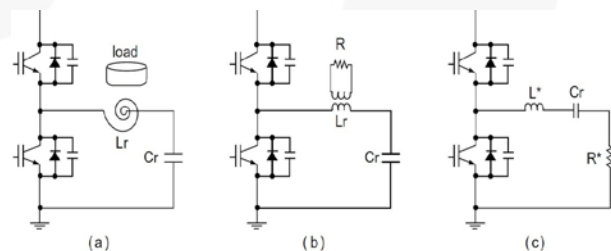

Figure 9. Equivalents of the Resonant Circuit

Operation Theory

By connecting the IGBT switching circuit, S_1 and S_2 , in parallel to diodes D_1 and D_2 ; current loss is minimized. When S_1 is turned off, D_2 helps S_2 stay on zero voltage / current before being turned on, substantially reducing current loss (the same is the case with S_1). There is no reverse-recovery problem as the voltage on both sides remains zero after the diode is turned off. However, as the switching circuit is turned off at around the upper limit of voltage and current, some switching loss results on turn-off. Capacitors C_1 and C_2 , acting as turn-off snubbers connected in parallel to S_1 and S_2 , keep this loss to a minimum. Upon turn-on, the switching circuit starts from zero voltage / current, so these turn-off snubbers operate without loss.

The configuration of a half-bridge series resonant inverter in Figure 8 can be simplified as an equivalent circuit illustrated in Figure 10. Figure 11 is a waveform of a frequency cycle in each part of the main power circuit. Turn on S1 when the current of the L*-Cr resonant circuit flows in the opposite direction through D1 (S1 and S2 remain off). Until $t < t_0$, the resonant current flows in the opposite direction through D1, rather than passing directly through S1.

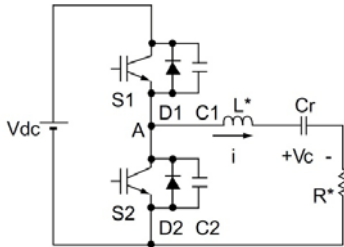

Figure 10. Equivalent of the Main Power Circuit

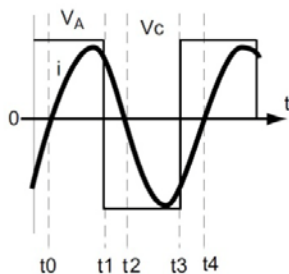

Figure 11. Waveform of the Main Power Circuit

MODE I: t_0-t_1

The resonant current flowing in an inverse direction changes its direction at the point of $t=t_0$ flowing through S1. In this mode, the DC-LINK voltage of V_{DC} lets the resonant circuit accumulate energy by supplying power through S1.

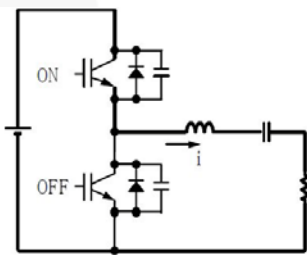

Figure 12. Mode I Operation

MODE II: t_1-t_2

When S1 is turned off at the point of $t=t_1$, the resonant current flowing through S1 begins free-wheeling through the D2 diode. In this process, a small amount of switching turn-off loss occurs as the S1 switch is turned off, while retaining some values in voltage and current. For the following this mode, S2 is turned on when $t_1 < t < t_2$. As the S2 switch remains at zero voltage / current, no switching loss takes place at turn-on. The reverse-recovery of D1 does not necessarily have to be fast.

After turning off S1, the resonant current passes, for a short period, through the snubber C1 before freewheeling to D2. A description of this period is not presented in this note.

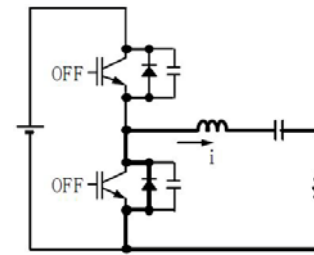

Figure 13. Mode II Operation

MODE III: t_2-t_3

Right after $t=t_2$, the current freely resonates and flows in an inverse direction through S2, which is already turned on. The resonant capacitor, Cr, serves as a source of voltage.

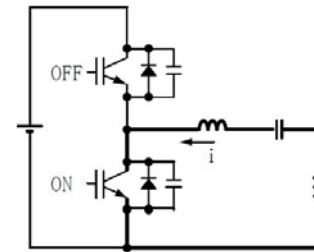

Figure 14. Mode III Operation

MODE IV: t_3-t_4

When S2 is turned off at $t=t_3$, the resonant current flowing through S2 starts freewheeling through the D1 diode. In this process, a small amount of switching loss occurs at turn-off. For the following this mode, the S1 switch is turned on at a certain point ($t_3 < t < t_4$). At this point, there is no switching loss at turn-on as the S1 switch remains at zero voltage / current. The reverse recovery of D2 does not have to be fast. In this mode, the energy of the resonant circuit is converted to V_{DC} passing D1. The operating mode after $t > t_4$ cycles from Mode I to Mode IV again, as described above.

In this process, the resonant current passes through the snubber C2, for a short period, before freewheeling to D1. This period is not explained in this note.

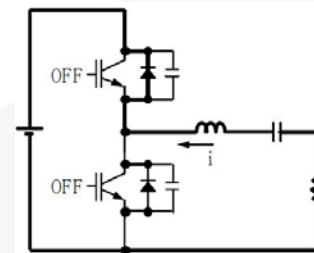

Figure 15. Operation

4.3. Determinants of Inductance and Capacitance of a Resonant Circuit

As heat energy is generated in the process of energy exchange between the inductor and the capacitor in the resonant circuit, the level of inductance and capacitance is an important factor. The following is a description of some factors that determine the value of the inductance level.

Power Consumption

As the most common size of a rice cooker is 1.8 liter (for 10 persons), the overall power supply is designed for this capacity, which is a maximum of 1250 W.

AC Current

A half-bridge series resonant inverter is appropriate for a 220 V power source. So with $\pm 15\%$ buffer range, the voltage is designed to be set at 187 V to 253 V in 60 Hz.

Resonant Frequency

To avoid audio frequency, the resonant frequency is set at over 20 kHz. In this example, the frequency is 24 kHz.

Capacitance (C)

The computation of the resonant current is below. As the input current is the average of the resonant current, the input current of a cycle is computed as (resonant current/ 2π):

$$I = \frac{2\pi P}{V} = \frac{2\pi \times}{197 \times \sqrt{2}} = 29.7 [A] \quad (19)$$

The capacitance of a resonant capacitor is determined as:

$$C = \frac{I}{2\pi f V} = \frac{29.7}{2\pi \times 24000 \times 187\sqrt{2}} = 0.74 [\mu F] \quad (20)$$

In this note, the standard value of capacitance is 0.8 μF .

Inductance (L)

The inductance of the resonant inductor is computed by using the capacitance explained above into Equation (13).

$$L = \frac{1}{(2\pi f)^2 C} = \frac{1}{(2\pi \times 24000)^2 \times 0.8 \times 10^{-6}} = 55 [\mu H] \quad (21)$$

It is important to consider whether a coil, having a value of L above, is fit for the container. The value of L is determined by the thickness of the coil and the number of turns and errors.

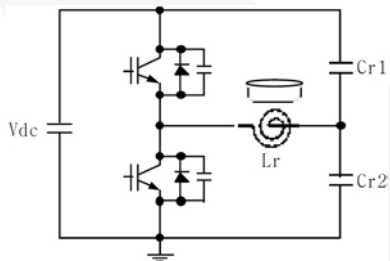

Figure 16. Common Type of Main Power Circuit

4.4. Actual Main Power Circuit

Figure 16 illustrates a main power circuit, which is used more commonly than the one in Figure 8. The resonant capacitor, Cr, is divided into two identical capacitors, Cr1 and Cr2 ($Cr1=Cr2$). By having two equal capacitors, the amount of current flowing through each capacitor is reduced

to half, while the voltage to the capacitors remains the same. This results in less heat generation caused by ESR and the RMS value of the ripple current in the DC-LINK capacitor is reduced to $1/\sqrt{2}$.

As the total amount of resonant current flowing through the inductor is equal in both systems, the amount of heat energy generated is as well. The amount of current in a capacitor, however, shows a difference. The flow chart of the current is not provided in this document.

4.5. Quasi-Resonant Inverter

There are a number of design methods for a power system employing a quasi-resonant inverter. Figure 17 features a block diagram of such a system in a streamlined form. This system was actually tested. The description of the heater is omitted in this document.

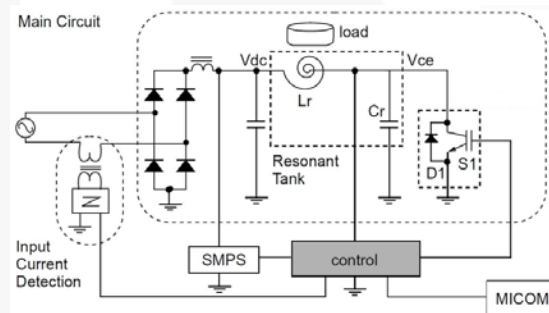

Figure 17. Quasi-Resonant Inverter

The total system block comprises of a main power circuit, input current detection circuit, control circuit, and SMPS circuit, as shown in Figure 17. The basic operating concept of a quasi-resonant circuit is similar to that of a half-bridge series resonant inverter in that heat energy is generated. However, the methods of controlling the gate in the switching circuit are totally different. Major functions of each block are as follows.

Main Power Circuit

The main power circuit features a quasi-resonant inverter, as shown in Figure 18. This consists of the Insulated Gate Bipolar Transistor (IGBT) and a diode connected in parallel. The circuit executes high-frequency switching. By turning on the IGBT while the diode is in turn-on state, it is possible to turn-on switching with the voltage and current remaining at zero. The resonant circuit is composed of resonant inductance (Lr) and resonant capacitance (Cr).

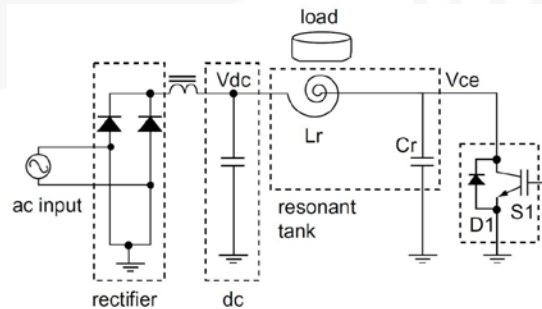

Figure 18. Main Power Circuit

Equivalent of a Resonant Circuit

Figure 19 shows the equivalent of a resonant circuit. The resistance in circuit (b) is equivalent to the load in circuit (a). These two circuits can be remodeled in a simpler form as circuit (c), which consists of R^* , L^* , and C_r . R^* is equivalent to R of transformer (b). L^* is the resonant inductor; combining L_r of the primary circuit, the leakage inductor, and the secondary inductor.

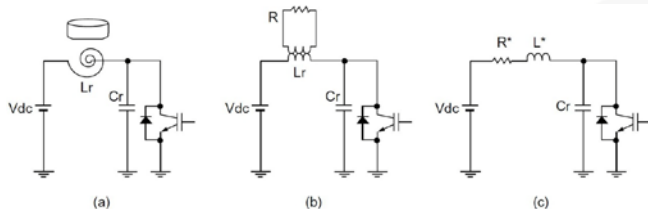

Figure 19. Equivalent of a Resonant Circuit

Operating Concept

Figure 20 illustrates an equivalent of the main power circuit. When D1, connected to the S1 switching circuit, is in turn-on state, zero voltage turn-on switching is available as V_{CE} of the circuit becomes zero. In this circuit, the switch must endure high internal pressure to accommodate the high voltage of V_{CE} administered to both ends of the switch.

Figure 21 shows the waveforms of each block of the main power circuit in a cycle. Initially, S1 is turned off by the control circuit when the current flowing through L^* and S1 reaches its peak. At this point, $V_C(0)=0$ V. There are four modes available, as shown below.

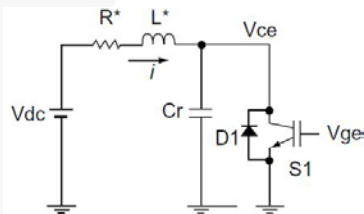

Figure 20. Equivalent of Main Power Circuit

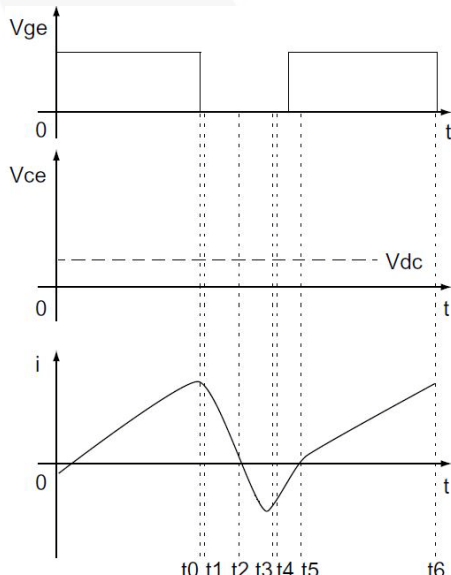

Figure 21. Waveforms of the Main Power Circuit

MODE I: t0-t1

The switching device is turned off at $t=t_0$. The V_{CE} is gradually increased by the capacitor (C_r) to become DC-LINK (V_{dc}) at $t=t_1$.

Even when the switch is turned off at $t=t_0$, the current keeps incrementing to reach its peak at $t=t_1$, when V_{CE} becomes equal to V_{dc} . At this point, the energy stored in the inductor begins to be transferred to the capacitor.

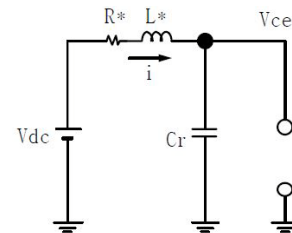

Figure 22. Mode I Operation

MODE II: t1-t4

As V_{CE} gets higher than V_{DC} after $t=t_1$, the current is decreased and reaches zero at $t=t_2$, while the resonant voltage reaches its maximum level. This is also the point where the transfer of the energy stored in the inductor to the capacitor is completed. The peak level of the resonant voltage has a direct relationship with the on time of the switch (Mode IV: t_5-t_6).

After $t=t_2$, the capacitor starts discharging the energy to the inductor, which causes the resonant voltage to decrement and reach its minimum level at t_3 , i.e. $V_{CE}=V_{DC}$. Passing $t=t_3$, the resonant current increases as $V_{CE}<V_{DC}$ and the discharge is completed at $t=t_4$.

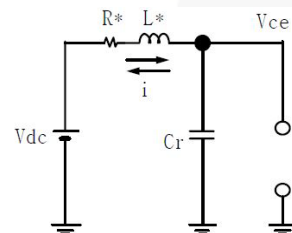

Figure 23. Mode II Operation

MODE III: t4-t5

At $t=t_4$, V_{CE} becomes zero and the parallel diode, D1, turns on naturally. Since the resonant current is flowing through D1, the voltage drop of the switch remains zero. Therefore, Zero Voltage Switching (ZVS) turn-on can be achieved by turning on the switch in this mode.

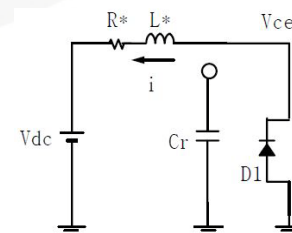

Figure 24. Mode III Operation

MODE IV: t5-t6

At $t=t_5$, the current direction changes and flows through the inductor. Therefore, the inductor starts to store the energy.

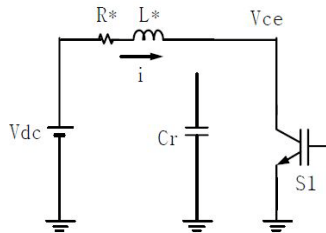

Figure 25. Mode IV Operation

At $t=t_6$, the switch is turned off, returning to Mode I. The output power of inverter can be controlled by a Pulse Frequency Modulation (PFM) with fixed off time and variable on time. The waveform of the resonant voltage changes whenever DC-LINK becomes LOW or there is any change in load impedance. The bandwidth of DC-LINK (V_{DC}) ranges from zero to maximum as the capacitor has a small capacity. The waveforms of the resonant voltage can be divided into three types, as shown in Figure 26.

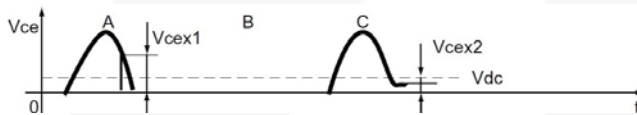

Figure 26. Waveforms of Resonant Voltage

A, B, C, and D are the waveforms of the voltage at early turn-on, normal loading, light loading, and late turn-on situation, respectively. If the waveform of C is generated under normal circumstances, it means that the value of the inductor or the capacitor is not properly set. When the waveform of A or D appears in a normal situation, the turn-off time of the switching frequency should be adjusted.

While the switching circuit is on, the amount of energy stored in the inductor must be large enough or resonance occurs in a light loading condition. In this situation, the resonant voltage has a finite value (V_{cex2}) other than zero, eliminating the freewheeling period of Mode III (t_4-t_5) and,

6. References

- [1] K.H. Liu and F.C. Lee, "Resonant switches-A unified approach to improve performances of switching converters," *IEEE INTELEC Conference Record*, pp.344~351, 1984.
- [2] K.H. Liu, R. Oruganti, and F.C. Lee, "Resonant switches-Topologies and characteristics," *IEEE Power Electronics Specialists Conference Record*, pp.106~116, 1985.
- [3] K.H.Liu and F.C. Lee, "Zero-voltage switching technique in DC-DC converters," *IEEE Power Electronics Specialists Conference Record*, pp.58~70, 1986.
- [4] W.A. Tabisz, P. Gradzki, and F.C. Lee, "Zero-voltage-switched buck and flyback converters- Experimental results at 10MHz," *IEEE Power Electronics Specialists Conference*, pp.404~413, 1987.
- [5] W.A. Tabisz and F.C. Lee, "Zero-voltage switching multi-resonant technique in DC-DC converters," *IEEE Power Electronics Specialists Conference Record*, pp.9~17, 1988.
- [6] W.A. Tabisz and F.C. Lee, "Development of power supply for induction heating," *Annual Project Report for ERL/ITRI of VPEC*, July 1991.
- [7] L. Grajales, W.A. Tabisz and F.C. Lee, "Development of power supply for induction heating," *Annual Project Report for ERL/ITRI of VPEC*, July 1992.

therefore, disabling a zero voltage turn-on. The following amount of energy stored in the capacitor is lost as a result of turning on the circuit:

$$W = \frac{1}{2} C_R V^2 cex2 f_s \quad (22)$$

The quality factor (Q) of the resonant circuit must be properly maintained to keep the maximum level of energy stored in the inductor or capacitor as high as possible. If Q is too large, it is harder to generate heat energy. This has a lot to do with the container material.

The following computation summarizes the above:

$$Q = \frac{\omega L}{R} = \omega \frac{Li^2}{Ri_2} \quad (23)$$

= energy stored in L/ energy consumed by load in each cycle.

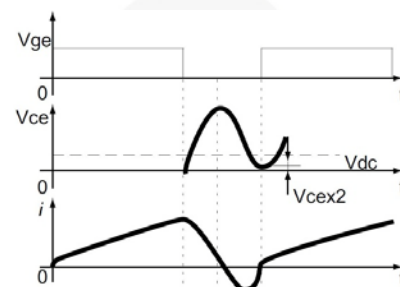

Figure 27. Waveforms at Non-Zero Voltage Turn-On

5. Conclusion

This concludes the overall description of the IH system. Understanding the basic concepts of induction heating and a power system with a resonant inverter should precede any attempt at developing IH system applications.

- [8] L. Grajales, K.R. Wang and F.C. Lee, "Development of power supply for induction heating," *Annual Project Report for ERL/ITRI of VPEC*, July 1993.
- [9] W.C. Moreland, "The induction range: Its performance and its development problems," *IEEE Transactions on Industry Applications*, vol.IA-9, pp.81~85, 1973.
- [10] P.H. Peters, "A portable cool-surface induction cooking appliance," *IEEE Transactions on Industry Applications*, vol.IA-10, no.6, pp.814~822, 1974.
- [11] H. Omori, M. Nakaoka, H. Yamashita and T. Maruhashi, "A novel type induction-heating single-ended resonant inverter using new bipolar Darlingtion transistor," *IEEE PESC Proc.*, pp.590~599, 1985.
- [12] P. Jain and S.B. Dewan, "Starting problems associated with a transformer coupled load in a series inverter," *IEEE Transactions on Magnetics*, vol.24, no.6, pp.2895~2897, 1988.
- [13] G. Zaiser, G. Fischer, M. Bruckmann and H. Doht, "ZVS driver for voltage-controlled switches in resonant converters," *Power Conversion, June 1995 Proceedings*, pp.481~489.
- [14] H.W. Koertzen, J.D. van Wyk and J.A. Ferreira, "Design of the half-bridge series resonant converter for induction heating," *IEEE PESC Record*, vol.2, pp.729~735, 1995.
- [15] S. Hinchliffe and L. Hobson, "Review of solid state devices and circuits for HF electric process heating applications: Part devices," *Int'l Journal of Electronics*, vol.61,no.2,pp.143~167, 1986.
- [16] S. Hinchliffe and L. Hobson, "Review of solid state devices and circuits for HF electric process heating applications: Part circuit," *Int'l Journal of Electronics*, vol.61,no.3,pp.261~279, 1986.
- [17] M. Orfeuil & A. Robin, *Electric Process Heating*, Battelle Press, 1987.
- [18] J. Davies, *Induction Heating Handbook*, McGraw-Hill, 1979.
- [19] M.G. Lozinskii, *Industrial Applications of Induction Heating*, Pergamon Press, 1969.
- [20] N. Mohan, T.M. Undeland & W.P. Robbins, *Power Electronics: Converters, Applications, and Design*, John Wiley & Sons, 1989.

DISCLAIMER

FAIRCHILD SEMICONDUCTOR RESERVES THE RIGHT TO MAKE CHANGES WITHOUT FURTHER NOTICE TO ANY PRODUCTS HEREIN TO IMPROVE RELIABILITY, FUNCTION, OR DESIGN. FAIRCHILD DOES NOT ASSUME ANY LIABILITY ARISING OUT OF THE APPLICATION OR USE OF ANY PRODUCT OR CIRCUIT DESCRIBED HEREIN; NEITHER DOES IT CONVEY ANY LICENSE UNDER ITS PATENT RIGHTS, NOR THE RIGHTS OF OTHERS.

LIFE SUPPORT POLICY

FAIRCHILD'S PRODUCTS ARE NOT AUTHORIZED FOR USE AS CRITICAL COMPONENTS IN LIFE SUPPORT DEVICES OR SYSTEMS WITHOUT THE EXPRESS WRITTEN APPROVAL OF THE PRESIDENT OF FAIRCHILD SEMICONDUCTOR CORPORATION.

As used herein:

1. Life support devices or systems are devices or systems which, (a) are intended for surgical implant into the body, or (b) support or sustain life, or (c) whose failure to perform when properly used in accordance with instructions for use provided in the labeling, can be reasonably expected to result in significant injury to the user.
2. A critical component is any component of a life support device or system whose failure to perform can be reasonably expected to cause the failure of the life support device or system, or to affect its safety or effectiveness.